

FALL PROTECTION GUIDELINE

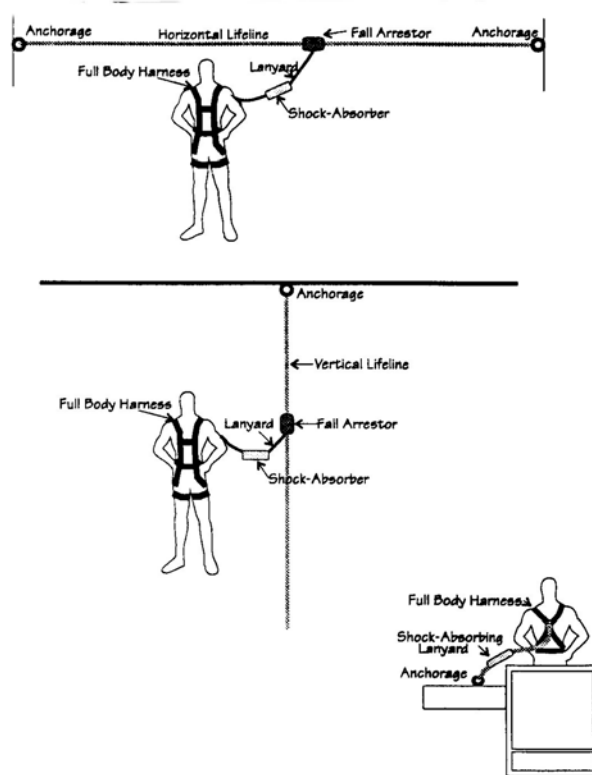

This education program provides a guideline for proper fall protection systems. It is intended to give contractors and workers practical information relating to the requirements of fixed barrier and personal protective equipment (safety harness and lifeline).

This education program contains general information. For specific regulatory requirements, please consult the appropriate Workplace Safety Health Act & Regulation adopted under the Workplace Safety and Health Act and the Canadian Safety Association Standards (CSA).

FALL PROTECTION – INTRODUCTION

Falls account for approximately 15 percent of all lost time injuries and fatalities in Manitoba workplaces. Falls not only happen in traditionally hazardous occupations, such as construction work, but can occur in all types of workplaces.

CATAGORIES OF FALLS

- Fall to work surface (i.e. slips)
- Fall against an object
- Fall from moving vehicle/equipment
- Fall from stairs, ramps and ladders
- Fall from one work level to the other
- Fall from edge of work level
- Fall into/through an opening

NOTE: In Manitoba, an employer must ensure that a worker is protected from falling a vertical distance of **3 meters (10 ft.)** or more, as required by Workplace Safety Health Act & Regulation.

EVALUATING THE RISK

When assessing the workplace for fall hazards, it is important to undertake a complete risk evaluation. This evaluation can be done in the form of job hazard analysis, where the work task is broken down into a number of distinguishable steps. The steps are then analyzed to determine the hazards and identify preventative measures to protect against the hazards. (See CCOHS “Job Hazard Analysis” Guideline.)

It is necessary to use a process such as this to determine where there is a risk of falls in the workplace. Once the hazards have been identified, preventative measures can be undertaken to protect against such falls.

CONTROL MEASURES

Fall Protection Systems Categories

- Surface protection (non-slip flooring)
- Fixed barriers (handrails, guardrails)
- Surface opening protection (removable covers, guardrails)
- Travel restraint systems (safety line and belt)
- Fall arrest systems (safety line and harness)
- Fall containment systems (safety nets)

The selection of the particular fall protection system to control the hazard to the worker is dependent upon the circumstances and the job task.

Ideally, the choice of a protection system will be one that removes the risk of falling entirely. For example, it is preferable to provide a fixed barrier to prevent a worker from falling, than personal protective equipment (safety harness and life line). In this way, the worker is never in a position where an actual fall may occur. Otherwise, the worker must rely on the personal protective equipment system to safely arrest the fall.

SURFACE PROTECTION

Non-Slip Floors

In order to prevent slips and falls on the same surface, it is a matter of providing a work surface free from tripping and slipping hazards. This can be accomplished by ensuring that good housekeeping practices are instituted in the workplace. It is important to keep the work area free of equipment and materials that are not required for the task at hand.

Floors that may become slippery due to the work operations should be provided with a non-slip type surface or coating that will provide a secure walking surface. Footwear with special soles may be also required. Material spills must be cleaned up immediately, especially if it creates a slippery surface.

FIXED BARRIERS

A fixed barrier must be capable of stopping a worker from proceeding past the edge of a work level or into a floor opening. Barriers may be permanent or temporary, depending on the circumstances at the workplace. Types include: guardrails, handrails, ladder cages, fencing, warning barriers.

Guardrail

Generally speaking, a guardrail is a permanent or portable structural system consisting of a top rail, mid-rail, and toe board secured to vertical posts intended to stop a worker from inadvertently stepping off a working level and falling to a level below.

Guard railing consists of a top rail at a height of between 900mm and 1060mm (36 to 42 inches) above the working surface with an intermediate rail at between 450 and 530 mm above the working surface (18 to 21 inches).

The guard railing must be capable of resisting a static load of 900 newtons (200 pound force) at any point along the rails. When guard railing is constructed of wood, all members shall be at least nominal 38 by 89 mm (1 ½ by 4 inches) with a span of no more than 2.4 meters (8') between posts.

Where there is danger of materials or objects falling from the work surface to a working level below, a toe board 125mm (5 inches) in height is required to be secured to the guardrail posts.

Guardrail posts must be capable of supporting any loads applied to the top rail. They must be securely attached to the base and braced where necessary to remain solid and secure. Posts are not to exceed a maximum spacing of 2.5 meters (8 feet) apart.

There are many different variations of guardrails, including wood-slat, wire rope, steel frame, safety fencing, tube and clamp, perimeter netting and others. Any of these variations is acceptable, as long as the system meets the basic design characteristics as mentioned previously. For example, where wire rope (cable) is used for guard railing, it must be tensioned to provide equivalent strength protection as a wooden guardrail system with a top and intermediate rail.

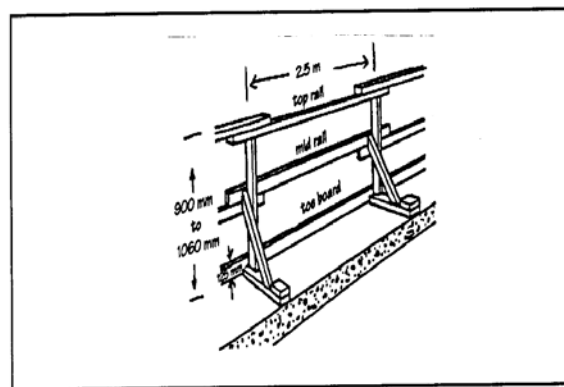

EXAMPLES OF GUARDRAILS

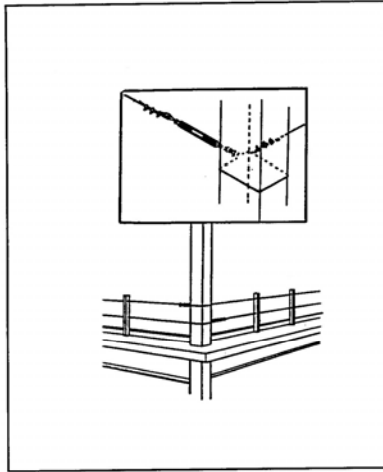

wire rope guardrail

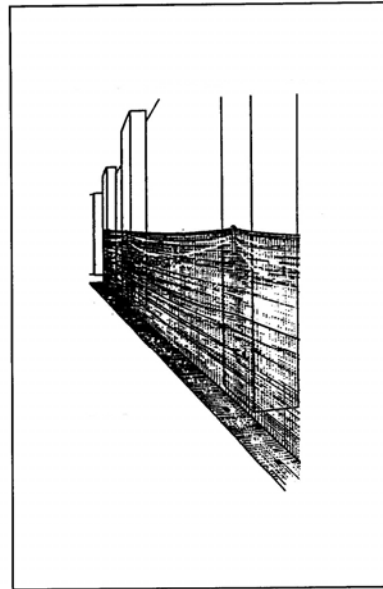

**perimeter net type
guardrail**

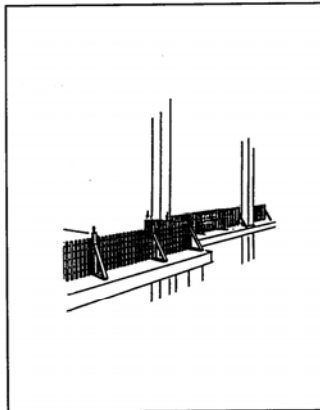

**wood slat type
guardrail**

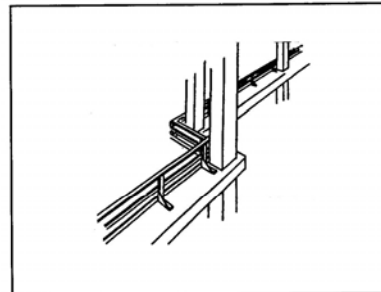

**standard wooden
guardrail**

Prior to and during installation of guard railing, it is essential that a safety harness and an independent lifeline, properly secured to an adequate fixed anchor is used by each and every worker who may go near any open edge and may be exposed to the risk of falling a distance exceeding 3 meters (10 feet).

Where a guardrail is temporarily removed, warning signs or warning tape should be used to mark off the hazard area.

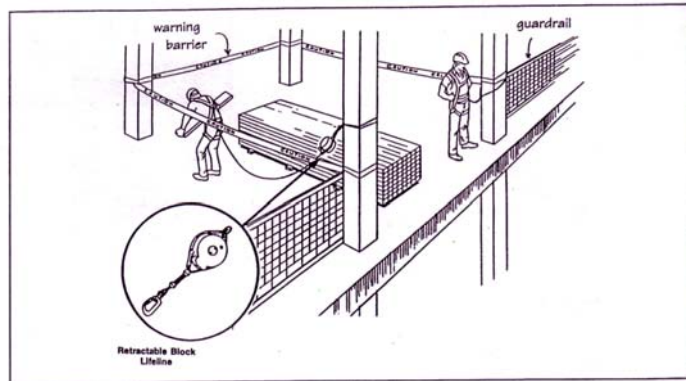

Warning Barriers

A warning barrier is used to indicate to workers that they are approaching a hazardous work area where a potential to fall exists. The warning barrier is used when it is not reasonably practicable to provide fixed barrier protection, or a guardrail has been temporarily removed from an area.

This system may utilize a cable, rope, or a fence system which is set up at least 2 meters from the work surface opening or edge. The effectiveness of this type of system is increased when high visibility flagging or other means is used to mark the warning barrier.

A warning system is not a substitute for guardrailing as it is usually of lesser strength and offers no protection to the worker who must go near the edge of a work area. Workers who are required to go beyond the warning barrier must use a travel restraint or fall arrest system. Lifelines must not be tied to the warning system or barricade.

Handrails

On the open side of stairs, ramps and other similar means of access, proper handrails must be provided. These serve as both a physical barrier and a means of support to a worker moving up and down the access way.

Handrails should be designed same as a guardrail, with a top rail, intermediate rail and a toe board where workers may be working below.

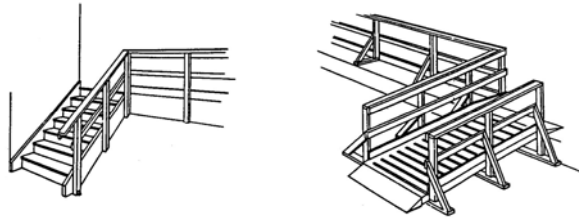

SURFACE OPENING PROTECTION

Guardrails/Floor Coverings

Surface openings and other walking surfaces where workers have access must be protected by guard railing, or secured wood or metal covers. The covering must be capable of supporting all loads to which it may be subjected. The covering must also be identified to indicate that there is an opening below.

When plywood is used to cover openings, the minimum thickness shall be 19 mm (3/4") with proper support for the plywood.

If work must be undertaken near unprotected openings from which a worker could fall 3 meters (10ft) or more, access must be restricted to workers who are wearing full body safety harnesses and lifelines secured to proper anchorage. As soon as the necessary work is completed, the opening should be protected by guard railing or adequate covering.

REMEMBER: IF A FIXED BARRIER OR SURFACE COVER IS REMOVED FOR ANY REASON, PROPER TRAVEL RESTRAINT OR FALL ARREST SYSTEMS MUST BE PROVIDED FOR ANY WORKER WHO BECOMES AT RISK OF FALLING.

SURFACE OPENING PROTECTION

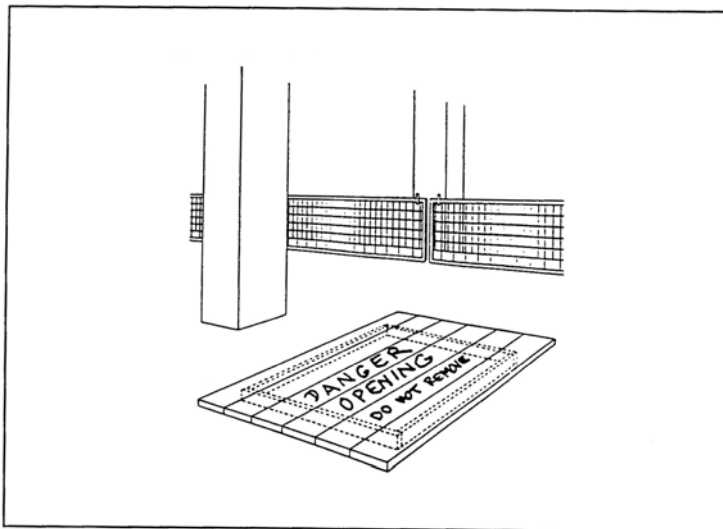
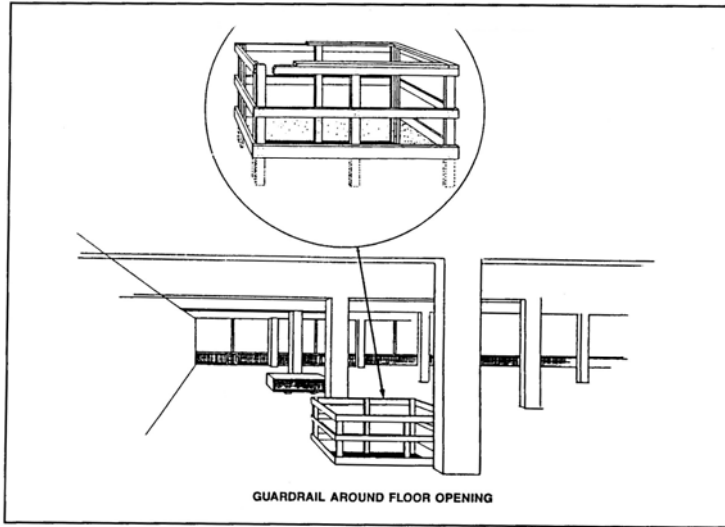

TRAVEL RESTRAINT SYSTEMS

Safety Belts/Lifelines/Lanyards/Anchorage

A travel restraint system is intended to limit a worker's movement so the worker is unable to reach a location where there is risk of falling.

The restraint system is made up of a safety belt (or safety harness), lifeline and/or lanyard and anchor. The safety belt is secured to a lifeline that has a fixed length, which is attached to a secure anchor. The length of the lifeline is such that the worker can only proceed to within approximately 1 meter of an opening or edge. Under no circumstances should a travel restraint system be rigged so that a worker is in a position to fall.

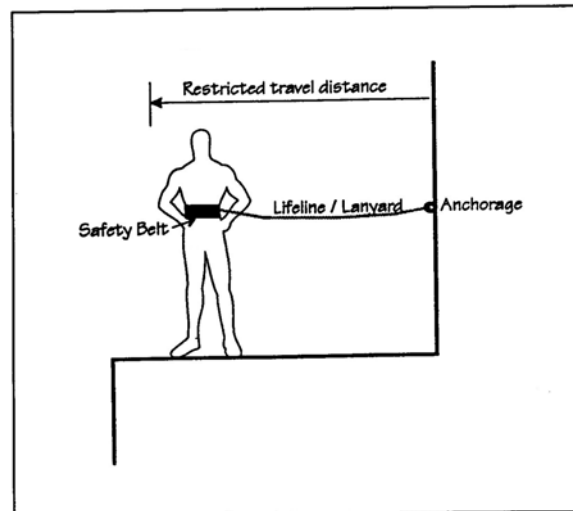

Seat Belts

A seat belt may be considered a "travel restraint system", since it serves as a device to limit movement when a force is applied to the user. The use of seat belts most often applies to operating motor vehicles and mobile equipment. The seat belt prevents the operator or passenger from falling out of the protective compartment of the equipment. This is much safer than being thrown from the equipment to a surface or object. All mobile equipment that is equipped with ROPS must have seat belts installed. Any worker operating the equipment must wear the seat belt at all times the vehicle is in operation.



SAFETY BELTS ARE NOT TO BE USED AS FALL PROTECTION!

FALL ARREST SYSTEMS

A fall arrest system differs from a travel restraint system. Unlike travel restraint, a fall arrest system does not prevent a fall; it reduces the chance of injury when a fall takes place.

A complete fall arrest system consists of an anchorage point, lifeline, fall arrestor, lanyard, shock absorber, and full body safety harness.

A 100kg (220 lb.) worker free falling 1.0 metres (3 ft.) generates an impact force of approximately 12kN (2700 lbs).

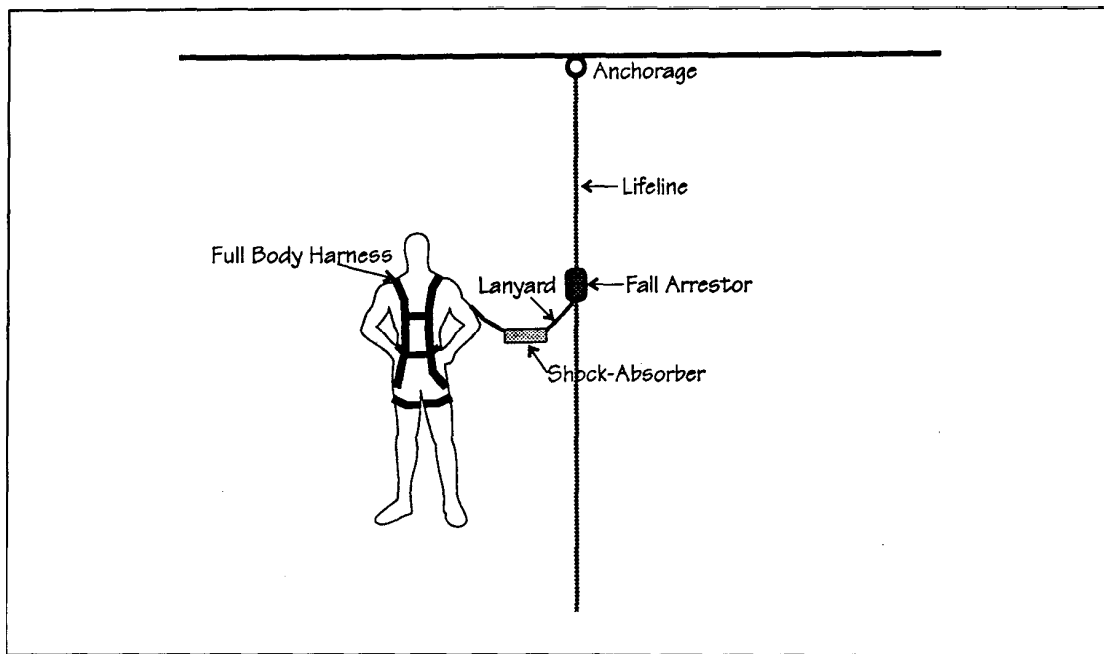

Specifications for a Fall Arrest System

1. Anchorage point - The anchorage must be capable of supporting a static load of 22.2 kN (5000 lbs) in any direction, with proper provision to accept a lifeline connection. If the anchor is exposed to the elements, it must be corrosion resistant. *(The minimum thickness of an eyebolt type anchor is 19mm (3/4") with a 38mm (1 1/2 ") opening diameter.)*

2. Lifeline - This is the part of the system that is attached to the anchor point and the user of the system. Lifelines must have a minimum strength equivalent to 60mm (5/8 inch") diameter polypropylene fibre rope. Lifelines must be properly secured to the anchorage point and be protected from abrasion or damage along their full length. Lifelines may run vertically or horizontally (installed between two or more anchors), depending on the application. Temporary lifelines are made of wire or synthetic rope. Permanent systems may be made of rigid steel, aluminum rails, wire ropes, or similar materials.

3. Fall arrestor (rope grab) - This is a device that automatically locks onto the lifeline when a fall occurs. It is fitted between the lifeline and lanyard and normally slides freely on the lifeline until there is a sudden downward motion. When this sudden motion occurs, the fall arrestor "grabs" the lifeline and holds firmly.

Fall arresting mechanisms are also built into retractable lifeline devices, that play out and retract as necessary, but hold fast in the event of a fall, (similar to a seat belt in an automobile).

4. Lanyard - A lanyard is an approved device located between the fall arrestor and the worker's safety harness. Lanyards should conform to CSA Z259.11-05 "Fall-Arresting Safety Belts and Lanyards for the Construction and Mining Industries".

5. Shock Absorber - This is a device that limits the force applied to the user when a fall occurs. It is designed to absorb the kinetic energy of the fall as the worker is stopped. The shock absorber prevents both injury to the worker and the amount of force transferred to the lifeline and anchor. A shock absorber must be capable of supporting a static force of at least 2kN (450lbs) without exceeding the allowable unit stress for each material used in the fabrication of the anchor point. It may be a separate device or built into the lanyard design. Lanyards should conform to CSA Z259.11-05 "Shock Absorbers for Personal Fall Arrest Systems".

6. Full Body Safety Harness - This is a device designed to contain the torso and pelvic area of a worker and to support the worker during and after a fall. A Grade A full-body safety harness conforming to Canadian Standards Association CAS-Z259.10-06 "Full Body Harnesses" is the type to be used for a fall arrest system.

Lifelines may be of the fixed length type, adjustable with rope grab or self adjusting (retractable) type. Shock absorbing mechanisms are available either incorporated into the lanyard or as an add-on and are recommended to be used to lessen the shock to the worker.

Horizontal Fall Arrest System

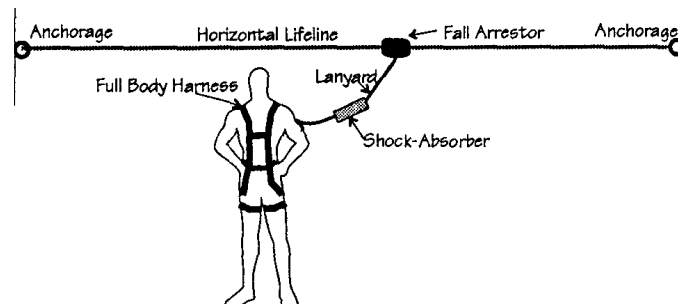

NOTE; A fall arrest system must be rigged to limit the fall of a worker to a maximum of 1.2 meters (4 feet).

Retractable Lifeline Fall Arrest System

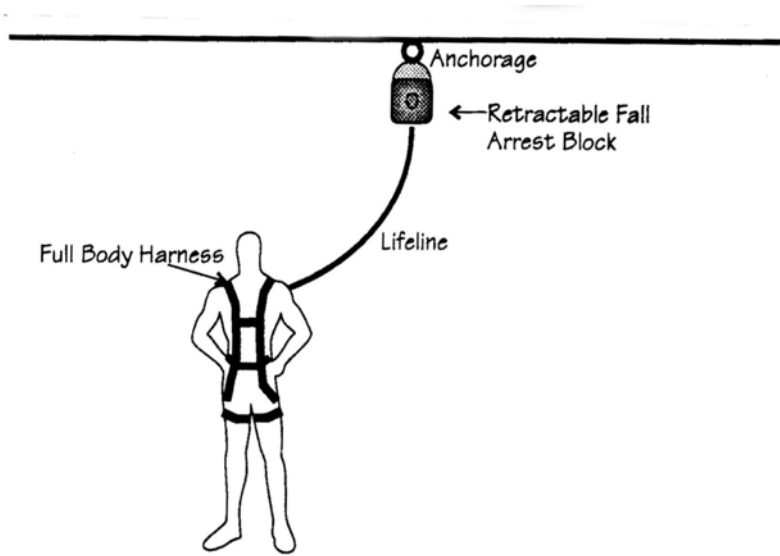

Sloped-Roof Fall Arrest System

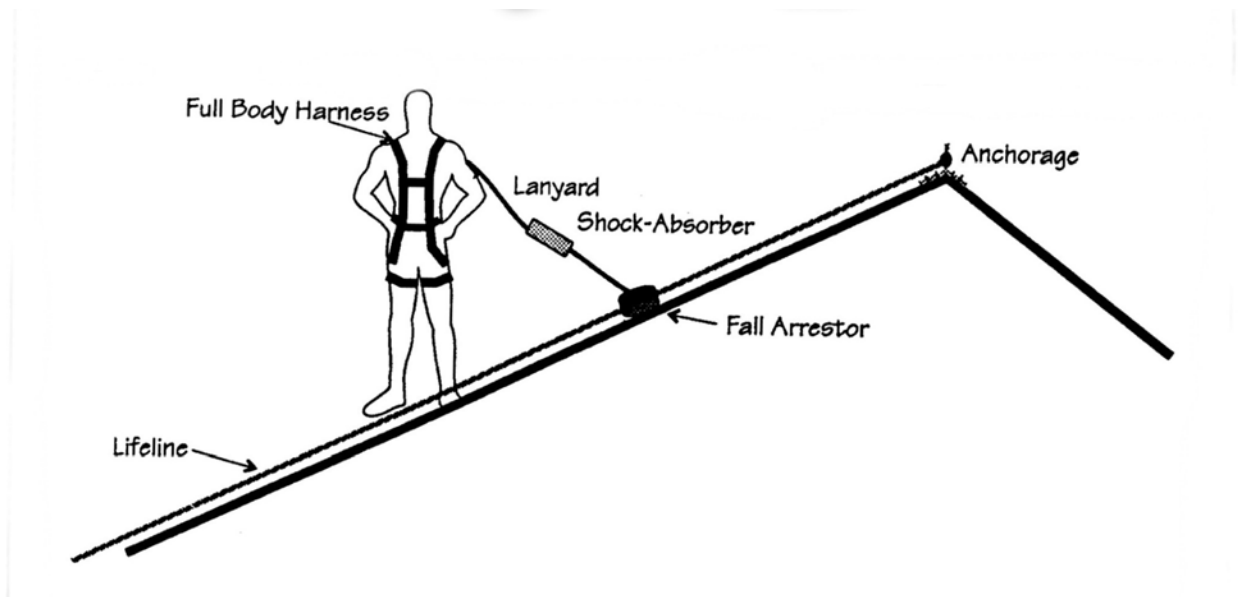

FIXED LADDERS

Vertical fixed ladders should be provided with a means to protect a worker from falling. This may consist of a ladder cage or a fall arrest system.

A ladder cage is a permanent structure attached to a ladder that provides a barrier between the worker and the surrounding space. It serves only as a support to a worker, if the worker needs to rest against the barrier. It does not provide complete fall protection on its own. However, it could be used in conjunction with a full body harness and lanyard. The worker would be able to secure the rung or side rail of the ladder at any time during the climbing of the ladder. This still does not provide complete fall protection.

A much better approach is to provide a complete fall arrest system into the ladder design. This could be a permanently installed metal rail or wire rope anchoring system with an automatic fall arresting device. The automatic fall arresting device would travel freely on the reel or cable, allowing the worker to use both hands while climbing up or down. Should the worker slip or fall, the device would lock instantly and limit the worker's fall to a matter of inches.

Another possibility is to mount a retractable fall arresting device to a fixed anchor at the top of the ladder. The worker would then be equipped with a full body safety harness secured to the end of the retractable lifeline. The worker would be in a position to move up and down the ladder, at all times protected.

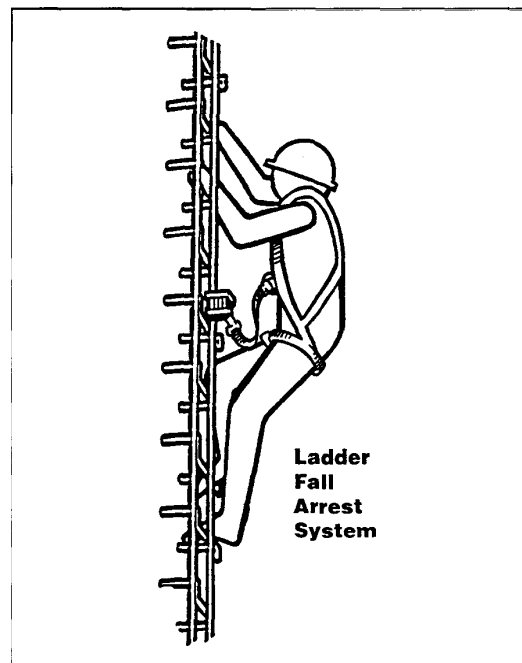
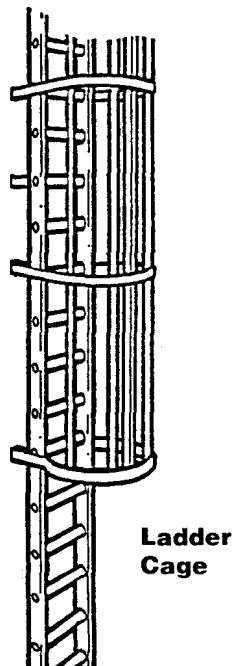

AERIAL DEVICES

Fall Protection systems are required for all workers working at elevation from aerial devices. These devices include ladder trucks, aerial baskets or bucket trucks, crane suspended lift baskets, and other similar devices that carry a worker to an elevated work position.

A proper fall arrest system must be incorporated into the work procedure, consisting of a full body harness, shock-absorbing lanyard and suitable anchorage.

Examples of the types of systems are shown below.

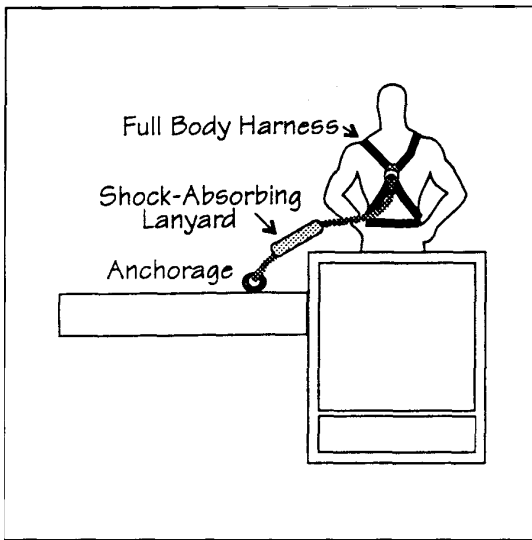

Bucket Truck

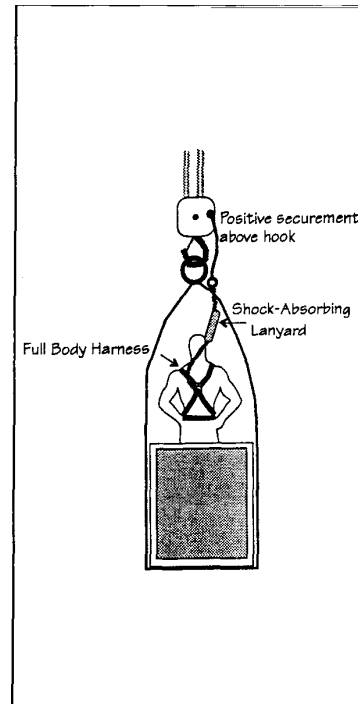

**Crane Suspended
Work Platform**

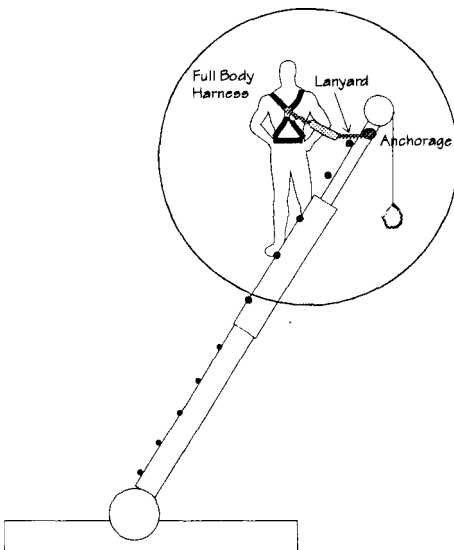

Ladder Truck

FALL CONTAINMENT SYSTEMS

Safety Nets

Where it is impractical to provide a fixed barrier of fall arrest systems, an alternate solution is the provision of safety nets. Safety nets are used most often where it is difficult or impossible to arrange for guardrailing or to provide a proper anchoring and lifeline system for fall arrest. The most common applications for safety nets are bridge work and structural steel erection.

Safety nets shall be designed, installed, tested and maintained in accordance with ANSI Standard A10.11-1989. (See reference next page.) The net shall be installed so that it extends 2.5 metres (8 feet) beyond the edge of the work area and not further than 7.7 metres (25 feet) below the working surface.

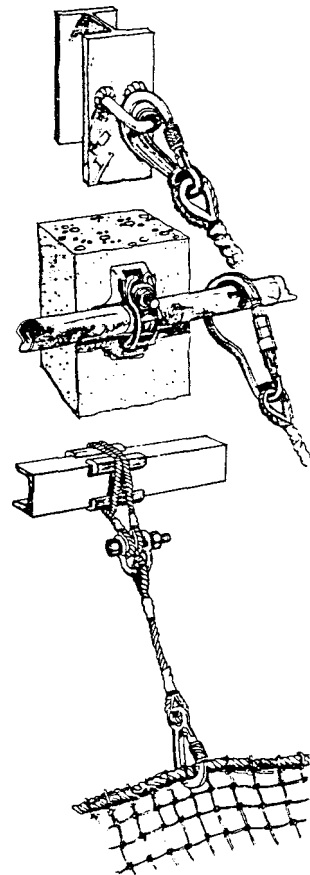
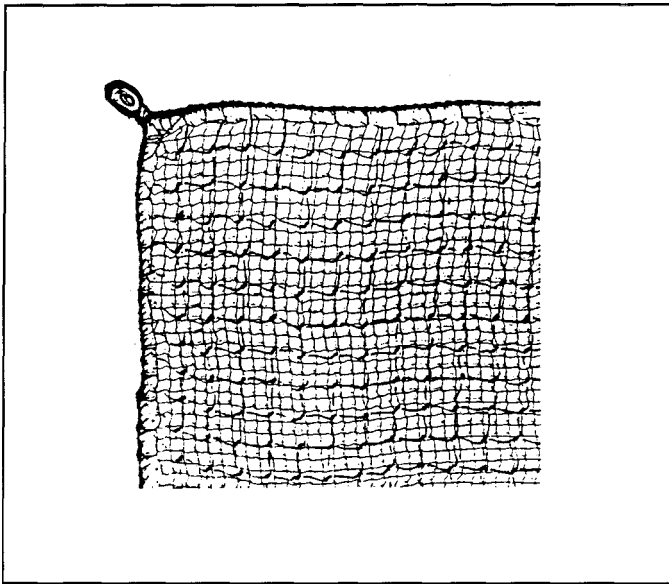

Safety Net and Securement

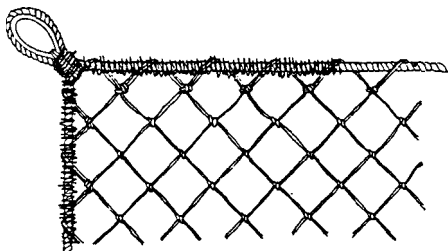

FALL PROTECTION
REVIEW QUESTIONS

NAME _____

DATE _____

PART 1 - FILL IN THE BLANKS WITH THE CORRECT ANSWERS

1. To prevent tripping and slipping hazards, good _____ practices must be implemented in the workplace.
2. Fall protection is to be used where there is a risk of a worker falling a vertical distance of _____
3. Workers who go beyond the warning barrier must use _____.
4. What are the three main components of handrails?
a) _____ b) _____ c) _____
5. The length of a lifeline should be rigged so as to prevent the worker from proceeding to within _____ metres of edge or opening.
6. A 220lb. worker falling 3ft generates an impact force of approximately _____ lbs.
7. Anchorage exposed to the elements must be _____ and be capable of supporting _____ lbs in any direction.
8. Minimum thickness of an anchor eye bolt should be _____ with an opening of _____ " in diameter.
9. A lifeline must have the strength of _____ " diameter polypropylene fibre rope.
10. When guardrails are temporarily removed the area should be marked off with _____.

PART 2 - ANSWER TRUE OR FALSE TO EACH OF THE FOLLOWING

- T F 1. In Manitoba, a worker must be protected from falling a vertical distance of 3 metres/10 ft or more?
- T F 2. Top guardrails must be 36" to 42" above working surface?
- T F 3. Guardrails constructed of wood must be made from at least 2" by 4" and should have a distance of no more than 8' between posts?
- T F 4. An anchorage point must be capable of supporting a static load of 5000lbs?
- T F 5. A fall arrest system must limit the fall to a maximum of 4ft?
- T F 6. Fall protection systems are required for all workers working from aerial devices?
- T F 7. Safety nets must extend at least 8' beyond the work area?
- T F 8. Safety nets can not be further than 15' below the working surface?

STANDARDS REFERENCES

CSA Standards

- Z259.1-1976** Fall-Arresting Safety Belts and Lanyards for the Construction and Mining Industries
- Z259.2-M1979** Fall Arresting Devices, Personnel Lowering Devices, and Lifelines
- Z259.3-M1978** Lineman's Body Belt and Lineman's Safety Strap
- Z259.10-M90** Full Body Harnesses
- Z259.11-M92** Shock Absorbers for Personal Fall Arrest Systems

ANSI Standards

- ANSI A 14.3** Safety Requirements for Fixed Ladders
- ANSI A10.11** Safety Nets Used During Construction, Repair, and Demolition Operations.

Acknowledgement

Some of the illustrations in this guideline are courtesy of the Construction Safety Association of Ontario and the Manitoba Workplace Safety & Health Branch.