

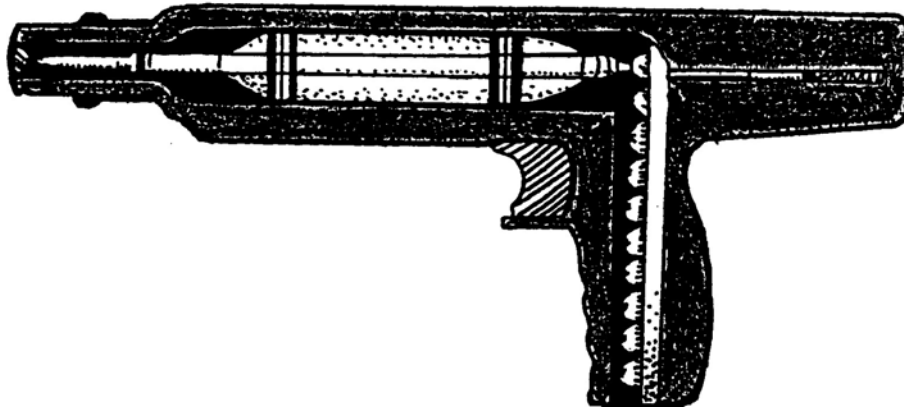

**CONSTRUCTION SAFETY
EDUCATION PROGRAM
#16**

EXPLOSIVE ACTUATED TOOL SAFETY



This education program provides a guideline for explosive actuated tools. It is intended to give contractors and workers practical information relating to the requirements of explosive actuated tools.

This education program contains general information. For specific regulatory requirements, please consult the appropriate Workplace Safety Health Act & Regulations adopted under the Workplace Safety and Health Act and Manufacturers standards and specifications.



GENERAL SAFETY GUIDELINES

The following is a condensed summary of general safety precautions. Refer to the individual instruction manuals published by the manufacturers for complete details.

1. **Always use the tool according** to the published tool operation instructions. The instructions should be kept with the tool.
2. **Never attempt** to override the safety features of the tool.
3. **Never place** your hand or other body parts over the front of the muzzle end of the tool. The fastener or piston can cause serious injury in the event of an incidental discharge.
4. **Use only genuine** manufacturer's fasteners, powder loads, and tool parts. Use of other material can cause **improper** and **unsafe** functioning of the tool.
5. **Operators** and **bystanders should wear eye** and **hearing protection** along with hard hats. Other personal safety gear as may be required should also be used.
6. Before using a tool, make sure it is **unloaded** and perform a proper function test.
7. **Do not guess** before fastening into any base material, always perform a centre punch test with the fastener to be used.
8. Always conduct a test, firing into a suitable base material with the lowest power load recommended for the tool being used. If this does not set the fastener, try the next higher power level. Continue this procedure until the proper fastener penetration is obtained.
9. Always point the tool away from operators or bystanders.
10. Never use the tool in an explosive or flammable area.
11. Never leave a loaded tool unattended.
12. Do not load the tool until you are prepared to complete the fastening. Should you decide not to make a fastening after the tool has been loaded, always remove the powder load first, then the fastener.
13. Always unload the tool before cleaning, servicing, or when changing parts, before work breaks, and when storing the tool.

14. Always hold the tool perpendicular (at a right angle) to the work surface and use the spall guard or stop spall whenever possible.
15. Always follow the required spacing, edge distance, and the base material thickness requirements.
16. Never fire through an existing hole or into a weld area.
17. In the event of a misfire, always hold the tool depressed against the work surface for a minimum of at least 15 seconds. If the tool does not fire, follow the published tool instructions.
18. Never carelessly discard or throw unfired powder loads into a trash receptacle.
19. Always store the powder loads and unloaded tool under lock and key.
20. Any unsafe tool shall be tagged unsafe and be repaired before use.
21. Do not use the fastener if the per-mounted fluting or washer has been removed, use of the tool could cause damage to the tool and its operator.

Explosive actuated fastening tools were designed and developed on the same basic principal as a hand gun and should be given the same respect.

There are many types of fastening tools in the industry, but only those using an explosive charge will be discussed in this program. It has become evident that a rapid method of fastening is required to achieve a reasonable speed to offset the increasing cost of labour in the construction industry.

Information, regulation and standards relating to these tools can be obtained through the Workplace Safety Health Act & Regulation **part 16** and licensed Manufactures and Dealers.

Workers, who use explosive actuated tools, must receive training in the proper handling and operating procedures before operating. This training is usually given by the Manufactures of the tool and/or their qualified authorized agents. A constant effort must be made regarding the training of explosive actuated tool operators in order to maintain a good incident prevention record.

SHOOTING PAINS

BY David Henderson

The only difference between this hand tool and a hand gun is that the bullet is a pin. Don't be caught looking down its barrel.

Its coffee time. The carpenter at the construction project is working with a powder-actuated tool to attach strapping to a concrete wall when he hears the lunch truck blowing its horn outside. He immediately puts down his tool and goes to join the line for coffee.

When he comes back, he starts chatting with the plumber who had joined him for the break. Without thinking, the plumber casually picks up the powder actuated tool and points it at the wall.

He pulls on the trigger a few times. Nothing happens. He pushes the tool against the wall and notices that the guard on the muzzle is spring loaded and that it moves in and out.

Curious, he puts his hand over the muzzle and pushes on it to test the strength of the spring. At the same time, he pulls the trigger again. This time it fires, and the plumber seriously injures two of his fingers.

DIRECT & INDIRECT ACTING TOOLS

Explosive actuated tools are as dangerous as handguns. Referred to as "**powder actuated**" or "**explosive actuated**," these tools use a powder charge to fire a pin or fastener into hard materials such as concrete, mild steel or masonry.

There are two types of powder actuated fastening tools: **direct-acting** and indirect-acting. In the direct-acting tool, the load essentially is a firearm cartridge without the lead bullet, acts directly against the fastener so that it is shot out the barrel of the tool, usually at high velocity into the material.



In an **indirect-acting** tool, the load acts on a piston within the tool's barrel, which in turn drives the fastener that is sitting at the end of the barrel. Because the mass of the piston acts on the pin, the pin's velocity does not need to be as high as in a direct-acting tool.

Most powder actuated tools used in construction are **low-velocity**.

Piston moves to strike the fastener.

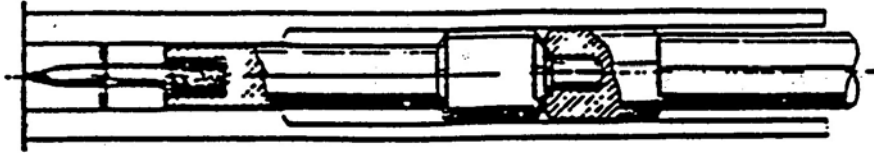

LOW VELOCITY SYSTEM:

A low velocity system is basically that of a piston-driven device that drives the fastener into the material.

In a low velocity tool, the load acts on a piston within the tool's barrel which in turn drives the fastener that is sitting at the end of the barrel. Because the mass of the piston acts on the pin, the pin's velocity does not need to be as high as the older style of high velocity tools which are outdated and in some provinces no longer in use because they were much more dangerous.

Low Velocity Systems



Piston and fastener move together.

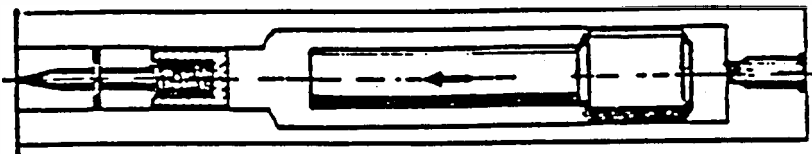

Piston moves to strike the fastener.

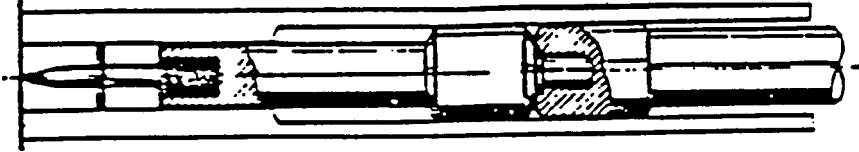

Piston and fastener are in contact at the time of firing.

POWDER LOADS

The energy source used to drive a powder actuated fastener into the base material is a self contained unit called a powder load. Specific load types are designed for each unique powder actuated tool.

The crimped tip on the load retains the powder in the casing. Wadded loads which have a plug in the front of the casing should never be used in tools designed for use with crimped loads such as low velocity, piston tools. The wadding material can cause the tool to clog or jam. Rim fire refers to the method of actuation.

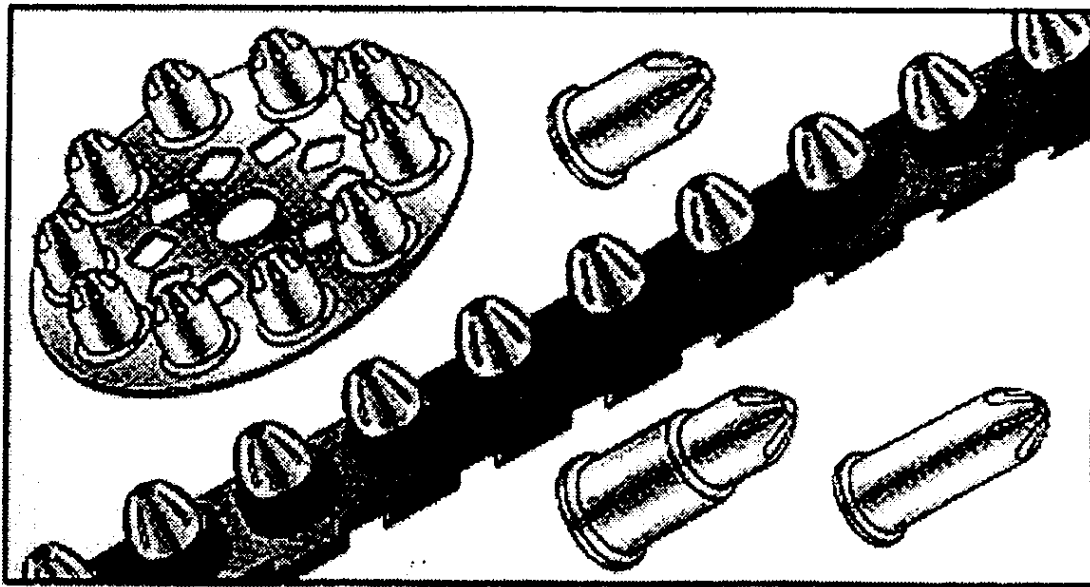

In a rim fire powder load, the primer is contained in the rim of the casing. When the tool is fired, the firing pin strikes the rim causing the primer to ignite which in turn ignites the powder contained in the main portion of the load.

Correct handling of powder loads demands the undivided attention of the operator. The explosive charges give the tools their proper speed and fastening

penetration. All cartridges must be handled carefully. Misfired and unused cartridges must not be left lying around the job site. The impact of a falling object could explode them. This could result in serious injury.

POWDER LOAD SELECTION

Use of the proper power level is critical to the success of a powder actuated fastening. Before selecting the proper power level, conduct a centre punch test for base material suitability.

To select the proper power level to be used with a specific fastener. Always perform a test, firing at the lowest power level recommended for the tool being used. On tools that have a variable power control, use the lowest possible setting. If the lowest power does not fully drive the fastener, try a powder load having the next higher power level. Continue this procedure until the fastener penetration is obtained.

MISFIRE

If a misfire occurs, the operator shall continue to hold the tool in the firing position against the work surface for at least 15 seconds then keep the tool pointed at the work surface until the powder load can be ejected as recommended in the manufacturer's operating instructions. An explosion could occur in these vital seconds even though the cartridge has misfired.

Some reasons for misfiring are:

- (A) Slow burning primer
- (B) Build-up of carbon in the breech
- (C) Malfunction in the firing mechanism

POWDER LOAD IDENTIFICATION

In the commercial market, cased powder loads are available in sizes ranging from .22 to .27 calibers.

The cartridges are coded by color and number. There is a maximum of 12 power levels and each is easily recognized. The lower-powered levels are numbered from one to six and are encased in brass. The higher-powered levels are numbered from seven to twelve and are encased in nickel.

The list below shows the color and number system.

Power levels for Charges

Brass-cased

Nickel-cased

6	Purple	12	Purple
5	Red	11	Red
4	Yellow	10	Yellow
3	Green	9	Green
2	Brown	8	Brown
1	Grey	7	Grey

LOADING PROCEDURES

It is a simple procedure to load the tool, but it is imperative that attention is given to this simple operation. The operator must be absolutely certain that the load is fully inserted in the breech.

A fully inserted load will eliminate any undue pressure from the breech plate coming into contact with the rim of the cartridge while closing the tool. All cartridges must be properly inserted and extracted according to the manufacturer's instructions.

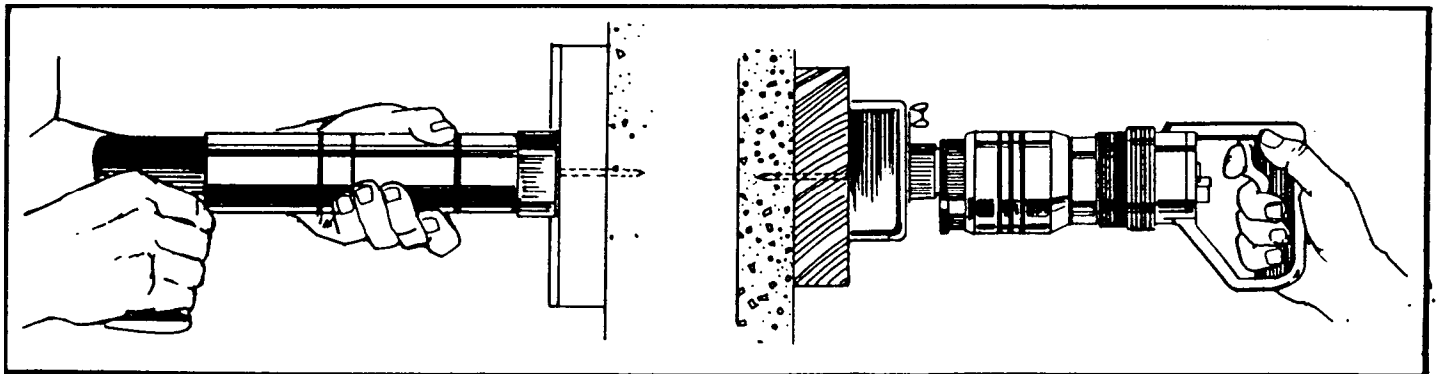

EXTRACTING CARTRIDGES:

Explosive Actuated Fastening Tools are required to have a mechanical device for extracting cartridges as part of the tool. However, there are occasions when, due to lack of knowledge on the part of the operator, or mechanical failure, a knife or other object has been used to extract the cartridge. The result has been the loss of fingers, or other serious injuries when the cartridge has exploded.

FASTENERS

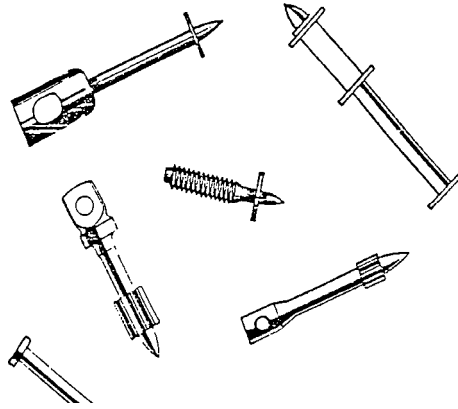

Fasteners are designed to obtain the maximum in penetrating and holding qualities while being safe to use. The material from which the fastener is made is necessarily harder than the material it is to penetrate. When the hardness of the material is not known it shall be tested by using a hand hammer to drive the point of the fastener into such material (centre punch test).

If the point of the fastener does not penetrate the surface, no attempt shall be made to use the tool on that surface.

FASTENER TYPES

Several fastener types are available including drive pins and threaded studs along with special application specific assemblies.

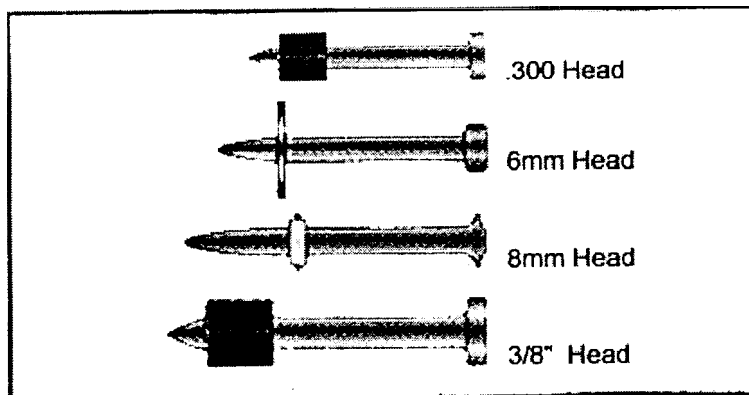

Drive pins are one of the most commonly specified type of powder actuated fasteners. They are used to fasten a fixture directly to the base material in one operation for permanent applications. Pins are available in three configurations, 0.300 head, 6mm head, 8mm head, and 3/8" head. Each of the head configurations has a corresponding shank diameter and a variety of lengths. Some drive pins designed for use in steel have a knurled shank to provide increase load capacities.

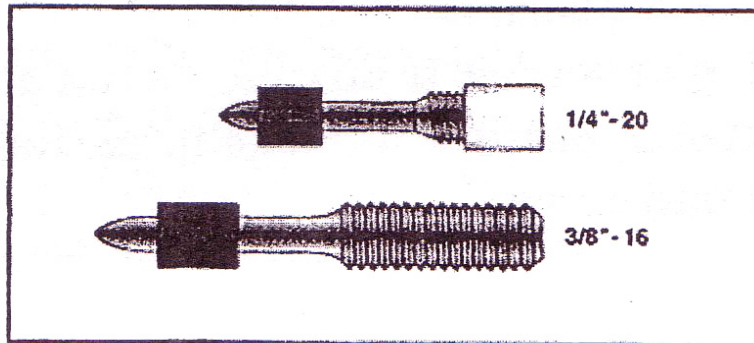

For applications where adjustment or removability may be required, threaded studs are available with both a 1/4" or 3/8" thread diameter. Each thread size has a corresponding shank diameter and is available in a variety of shank and tread lengths.

FASTENER GUIDANCE

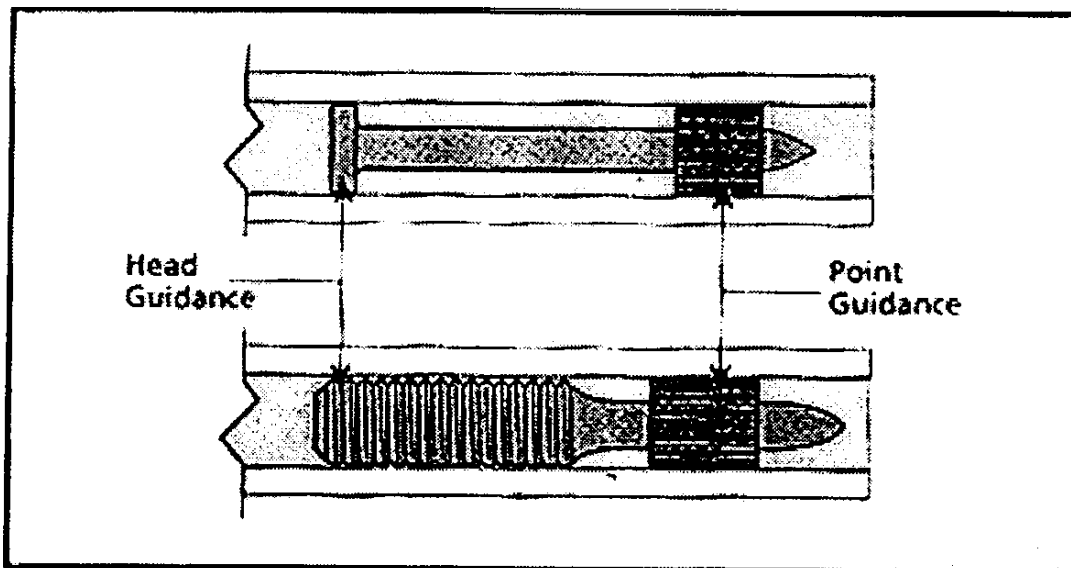

Both types of fasteners have pre-mounted plastic fluting or washers which hold the fastener centered in the tool guide prior to driving.

During the driving process, the fluting or washers provide guidance for the fastener head or threads.

1/4"-20 threaded studs also have a plastic cap to protect the threads of the fastener during the driving process and to provide head guidance.

If the fluting or washer is missing do not attempt the use the fastener, possible damage to the tool and its' operator could occur.

REVIEW QUESTIONS

TRUE OR FALSE

- T / F 1. A certified operator's card is not needed on low velocity tools.
- T / F 2. It is important to read the operator's instruction manual before operating the tool.
- T / F 3. Depending on the base material eye protection is not always needed.
- T / T 4. Safety shields or spill guards should be used whenever possible.
- T / F 5. The operator can place his/her hand over the muzzle, only when testing the muzzle spring guard.
- T / F 6. Test fastening should always be made on the lowest power load.
- T / F 7. In case of a misfire, the load should be pried out with a knife first.
- T / F 8. The fastening tool should only be used at a perpendicular angle when fastening to a base material.
- T / F 9. Horseplay should never be allowed at the work site before noon.
- T / F 10. Flammable and explosive areas are off limits when using a powder actuated tool.
- T / F 11. When not in use powder actuated tools should be stored in a safe secure place.